

verilux[®]
The Healthy Lighting Company™

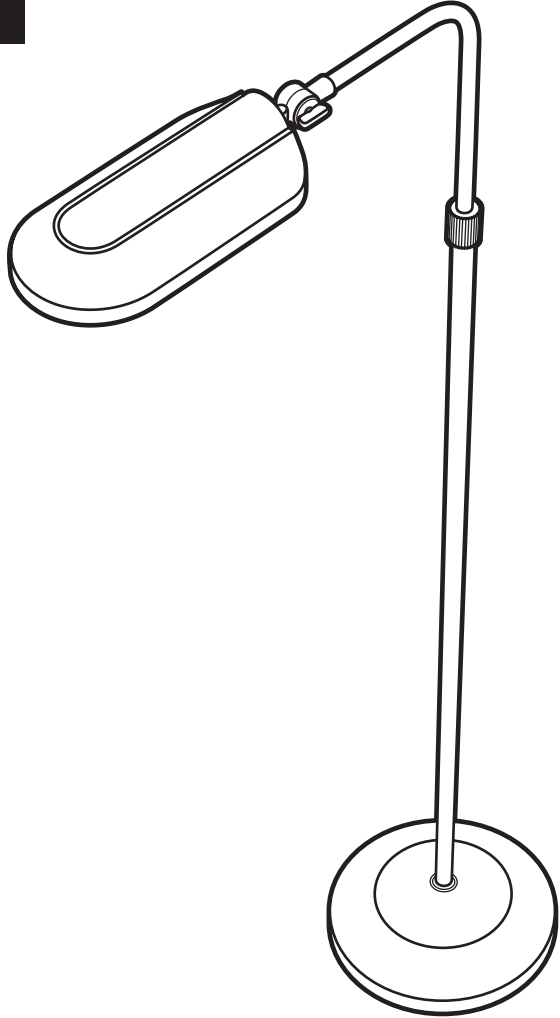

Heritage™ | Deluxe

Natural Spectrum® Floor Lamp

VF03



Dear Customer,

Thank you for purchasing the Verilux® Heritage™ Deluxe Full Spectrum Floor Lamp. You have received a quality product, backed by a three-year limited warranty. As a Verilux® customer, your satisfaction means everything to us. We look forward to serving you now and in the future.

Many other healthy lighting products are available through our catalog and online. Please visit us on the web at www.Verilux.com to learn about other great Verilux® products.

Have a Bright Day!

Nicholas Harmon
President and CEO

IMPORTANT SAFETY INSTRUCTIONS

SAVE THESE INSTRUCTIONS

Thank you for purchasing the Heritage™ Natural Spectrum® Deluxe Floor Lamp. Please read the following safety information before using. To reduce the risk of fire, electrical shock, or injury to persons:

- Do NOT dismantle.
- Do NOT alter power cord.
- Turn off/unplug and allow to cool before replacing bulb or cleaning.
- For indoor use only.
- The lamp is an electrical device. **DO NOT USE NEAR WATER**

GENERAL PRECAUTIONS

- Before plugging in the lamp, check to make sure the voltage corresponds with the main voltage of your location (120 volts).
- Do not use the lamp outside or in wet locations such as bathrooms. It is intended for indoor, dry use only.
- Not for use with light dimmers, timers, motion detectors or extension cords.
- This product may cause interference with radios, cordless telephones, or devices that use a wireless remote control, such as televisions. If interference occurs, move the product away from the device, plug the product or device into a different outlet, or move the lamp out of the line of sight of the remote control receiver.
- The light bulb may become loose during transit. To reinstall the light bulb, see the bulb installation instructions on page 8.
- Do NOT use lubricating agent in assembly; please see troubleshooting section if you are having difficulty assembling your lamp.
- Unplug from electrical outlet for extended periods of non-use or during lightning storms to ensure protection of the electronics.

GETTING STARTED

Main Parts & Controls

- A. Optix® Glare Control Filter
- B. Switch
- C. Lamp Head Swivel Knob
- D. Lamp Arm
- E. Height Adjusting Collar
- F. Upper Shaft
- G. Lower Shaft
- H. Lamp Base
- I. Power Cord
- J. Power Supply (Ballast)
- K. Bulb

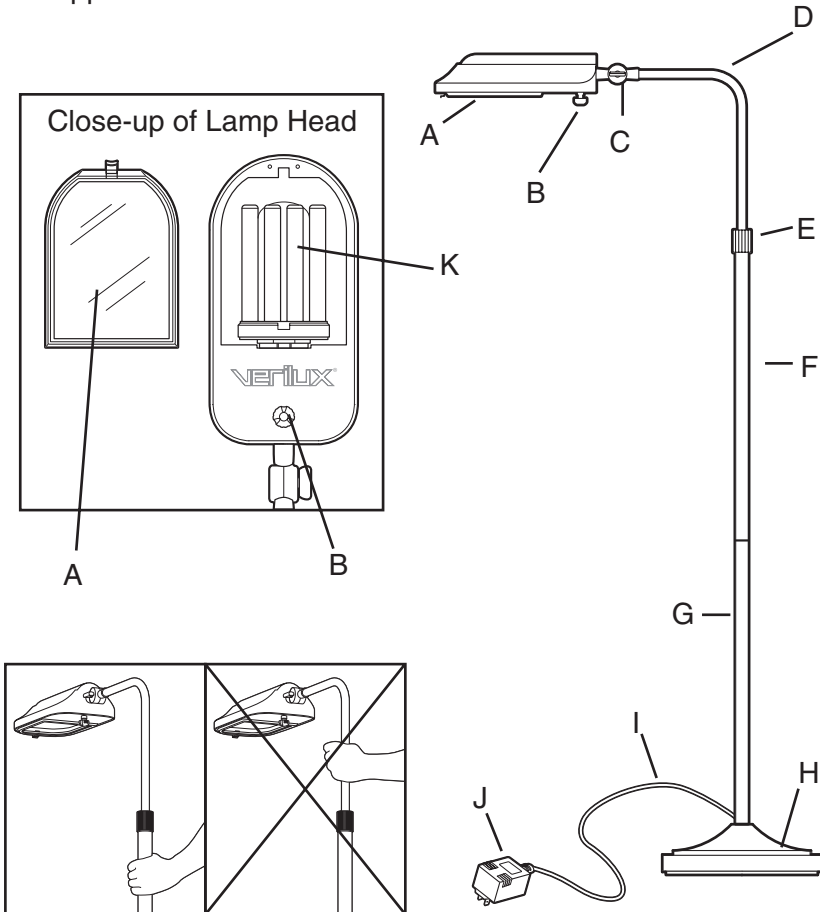

Attention!

Lift your lamp by the vertical shaft, NOT the lamp arm.

ASSEMBLY INSTRUCTIONS

Please Read Operating Instructions Carefully Before Using the Heritage™ Full Spectrum Floor Lamp:

1. Set lamp base on the floor and insert the lower lamp shaft (G) onto the base and screw clockwise to tighten. (Fig.1)
2. Pull the slack of the electrical cord through the lamp base. (I)
3. Loosen the height adjusting collar (E) to free lamp arm. (D)
4. With one hand holding the lamp arm (D), screw the upper shaft (F) onto the lower shaft. (G) (See Assembly Detail Below)
5. Tighten height adjusting collar to secure lamp arm.
6. To lift lamp head, loosen swivel knob (C), adjust head to desired angle. Tighten swivel knob.

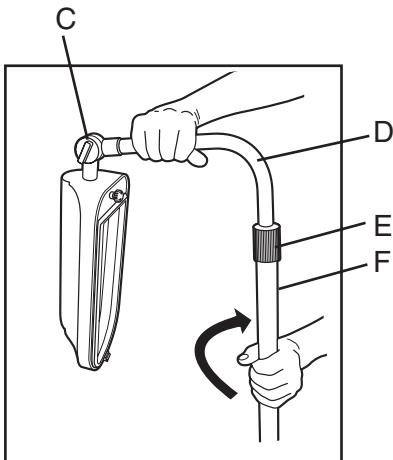

Assembly Detail

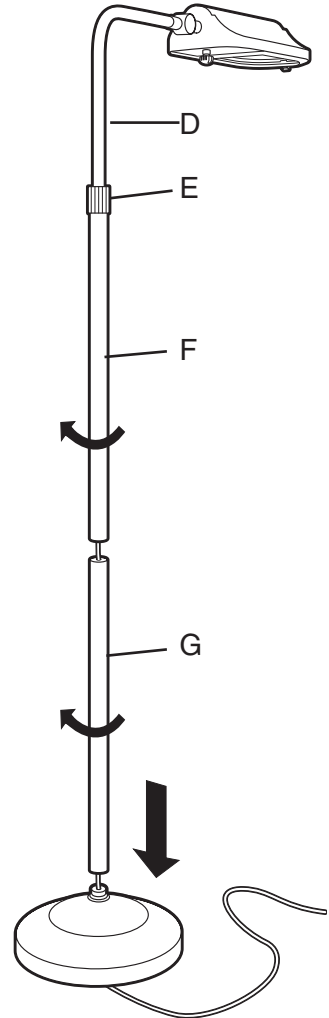

Fig. 1

ASSEMBLY INSTRUCTIONS cont.

7. Attaching the Optix® glare control filter:

- Remove glare control filter from protective plastic bag. Take care to hold filter by the edges only.
- Insert tabs on bottom of filter into opening. (Fig. 2)
- Press into place using thumb tab.
Do not touch or press on the filter material itself.

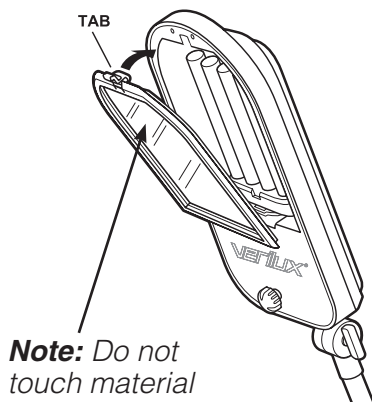

Fig. 2

8. Attach the ballast to the power cord. Use care to align the 4-pin plug properly. DO NOT FORCE – the 4-pin plug was designed to fit in only one orientation. (Fig. 3)

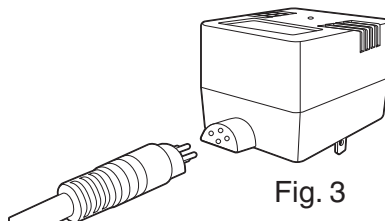

Fig. 3

9. Plug ballast into a standard 120V 50/60Hz outlet. Turn lamp on. The green LED indicator on center of the ballast should be illuminated. (Fig. 4) If the LED indicator does not illuminate, please refer to the troubleshooting section of this manual. (See page 9)

10. If bulb does not illuminate instantly, please refer to the troubleshooting section of this manual.

11. Adjust lamp brightness to the desired level (low-medium-high).

WARNING: Do not block vents on ballast. Vents are necessary for proper function of the ballast; blocking them may cause overheating of the ballast and increase risk of fire.

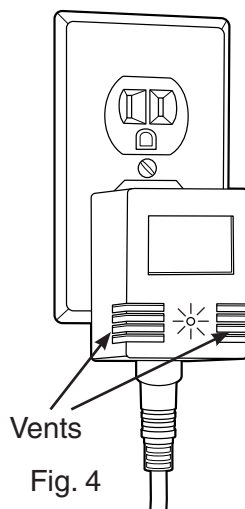

Fig. 4

ADJUSTING THE HERITAGE™ FLOOR LAMP

The Heritage™ Floor Lamp adjusts several ways:

1. To adjust lamp height – hold upper shaft (F) with one hand, loosen height adjusting collar. Raise or lower lamp arm (D) to desired height. Tighten collar. (Fig. 5)

Note: Do not stand on cord or otherwise restrict its movement while raising or lowering the height of the lamp.

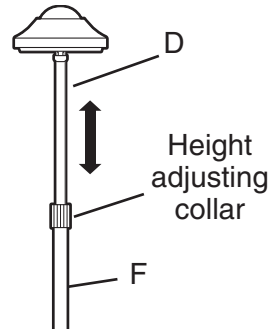

Fig.5

2. To rotate the lamp head right or left, loosen height adjusting collar, swing lamp arm to desired position. Tighten collar. Lamp arm rotates a full 360°. (Fig. 6)

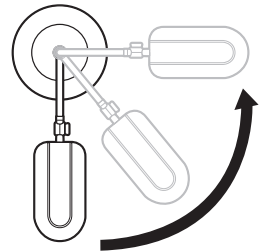

Fig. 6

3. To adjust lamp head angle up or down – loosen swivel knob counterclockwise, place head at desired angle, tighten swivel knob to secure. (Fig. 6)

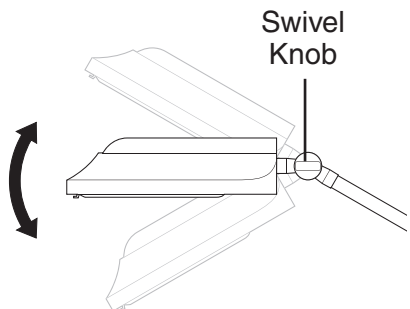

Fig. 7

4. To tilt lamp head toward you or away from you – simply move head to desired position. (Fig. 8)

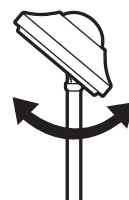

Fig. 8

BULB REPLACEMENT INSTRUCTIONS

Removal

1. Unplug lamp from power source.
2. To access the bulb, remove Optix® glare control filter by depressing the thumb tab and lifting it out.
3. Firmly hold bulb base (B) and pull bulb (C) from the socket (A) in an outward motion. (Fig. 9)

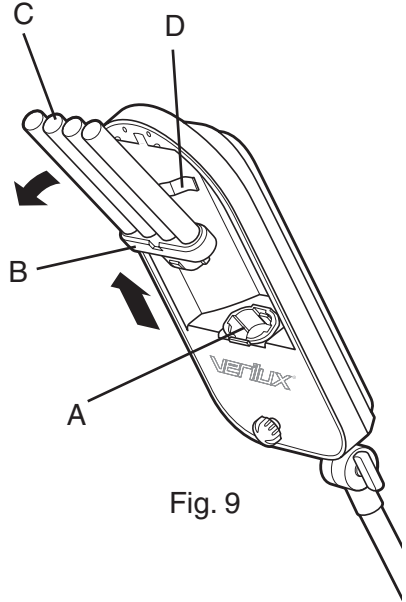

Fig. 9

Installation

1. Unplug lamp from power source.
2. Firmly hold base (B) and push bulb (C) into the socket (A).
3. Be sure bulb is firmly seated in the socket (see below) and snapped into the metal bulb clip (D). (Fig. 10)
4. Replace Optix® glare control filter.

YES

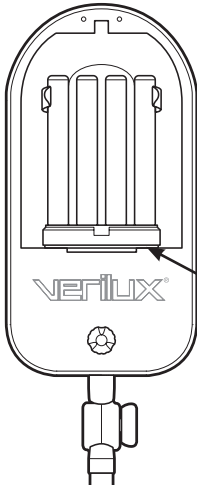
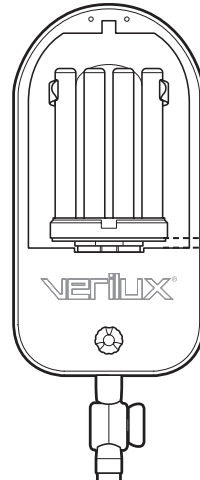

Fig. 10

No gap

Correctly seated bulb

NO



Notice large gap

Incorrectly seated bulb

TROUBLESHOOTING

Your Verilux® desk lamp uses advanced micro-electronics to power the revolutionary Trucolite™ bulb. These electronics are housed in a specially designed ballast located at the power plug. The LED indicator light on the ballast allows you to troubleshoot any problems with the lamp's function. When replacing your Verilux® ballast, take care to plug in the power cord properly. The 4-pin plug was designed to fit in only one orientation (See Assembly Instructions on page 5).

- Make sure all power connectors, cords, and plugs are inserted fully and securely.
- Be sure the bulb is securely seated into the socket. (See page 8).
- Unplug the lamp for a few minutes (this allows the electronics in the ballast to reset).
- Make sure there is power to the wall outlet or try another outlet.

PROBLEM	CHECK	SOLUTION
Light won't come on	Has the plug come loose?	Insert plug securely into wall outlet.
	Is the bulb old?	Check the bulb for blackening/darkening at the ends (an indicator of bulb life) and replace bulb.
	Is the bulb connected securely to the socket?	Be sure the bulb is securely seated into the socket, repeat the bulb installation process.
Blackening/darkening at ends of bulb	Is the bulb new?	Sometimes when a new bulb is turned on for the first time the tube will darken, but this will fade after a few minutes.
	Is the bulb old?	With older bulbs darkening of the tube indicates end of bulb life. (This doesn't affect operation except to reduce the amount of light available since the phosphor in that area has become inactive). Bulb replacement is recommended.
Light flickers	Has the plug come loose?	Insert plug securely into wall outlet.
	Is the bulb connected securely to the socket?	Be sure the bulb is securely seated into the socket, repeat the bulb installation process.
	Is the lamp connected to a dimmer switch?	Connect lamp plug only to wall outlet without a dimmer switch.

WARNING: Do not block vents on ballast. Vents are necessary for proper function of the ballast; blocking them may cause overheating of the ballast and increase risk of fire.

CARE & CLEANING

Your lamp is made from high quality materials that will last for many years with minimum care. You may want to periodically clean the lamp, using a mild non-abrasive cleaner and soft cloth. When cleaning, make sure you have turned off and unplugged the unit, and allowed sufficient time for the unit to cool. All liquid should be properly wiped away and dried prior to restoring power.

DO NOT USE SOLVENTS OR CLEANERS CONTAINING ABRASIVES, OR AMMONIA BASED CLEANERS

***Note:** Do not use any cleaning agents, including window cleaner, on the Optix® glare control filter. If needed, dust with a clean, dry cloth.*

WARRANTY

Three-Year Limited Warranty

ATTENTION! ONCE OPENED, PLEASE **DO NOT** RETURN THIS PRODUCT TO THE STORE WHERE IT WAS PURCHASED FOR REPAIR OR REPLACEMENT!

Many questions may be answered by visiting www.Verilux.com, or you may call our customer service department at 1-888-544-4865.

This limited warranty is provided by:

Verilux, Inc., 340 Mad River Park, Waitsfield, VT 05673

Verilux® warrants this product to be free from defects in material and workmanship for a period of three years from the date of the original retail purchase. During the limited warranty period, Verilux, Inc. will, at its option, repair or replace defective parts of this product, at no charge to the customer, subject to the following limitations. This limited warranty does not include any postage, freight, insurance or delivery fees. This warranty does not cover damage, defect or failure caused by or resulting from accident, external destruction, alteration, modification, abuse, misuse, or misapplication of this product.

If, during the first three years of ownership, this product fails to operate properly, it should be returned as specified below:

Please pack the defective product in its original protective packing and box, with a copy of your sales receipt, along with \$6.95 (check or money order to cover shipping and handling), and send to:

For U.S. Postal Service Only:

**Verilux Warranty
Service Center, c/o WTB**

P.O. Box 119, West Redding, CT 06896

For Fed Ex & UPS Only:

**Verilux Warranty
Service Center, c/o WTB**

32 Henry Street, Bldg 17A, Bethel, CT 06801

Please allow 4-6 weeks before you receive the repaired or replaced product.

ATTENTION: When returning a product, be aware that damage during shipping is the responsibility of the purchaser and will void any warranty claim. We recommend that you insure the shipment by shipper when returning this product or any parts. Be sure to return product in original packaging.

***Note:** Verilux® recommends using a quality surge suppressor on all electronics equipment. Voltage variations and spikes can damage electronic components in any system. A quality suppressor can eliminate the vast majority of failures attributed to surges and may be purchased at electronics stores.*

Due to ongoing improvements, actual product may have slight variations from the product described in this manual.

Please visit our web site at: www.Verilux.com



340 Mad River Park, Waitsfield, VT 05673

1-888-544-4865